

# User's guide

## Screw withdrawal resistance meter



Fakopp Enterprise Bt.  
H-9423 Ágfalva, Fenyő u. 26.  
Hungary, 2010  
[www.fakopp.com](http://www.fakopp.com)

# Screw withdrawal force meter

## Introduction

Screw withdrawal force is an indicator of the wood material strength, density and shear modulus. Fakopp Enterprise developed a portable screw withdrawal force meter. The applied screw diameter is 4mm, the length of the thread is 18 mm. The screw withdrawal force is a local parameter, but selecting a representative location on a beam it is a useful information in wooden structure evaluation.

The correlation coefficient between the screw withdrawal force and bending strength (MOR) is 0,72. The following figure shows the scatter graph. Dimension of the specimen was 4x6x80 cm.

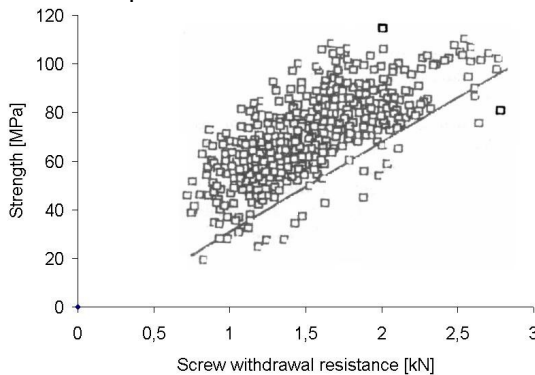

The correlation coefficient between the screw withdrawal force and density is rather high: 0,79.

The correlation coefficient between the screw withdrawal force and shear modulus is 0,86! The main deformation in the withdrawal process is shear. This is the reason of the high correlation value. Please find scatter graph below. Dimension of the specimen was 5x10x180 cm.

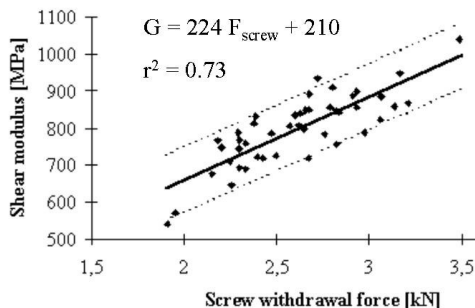

## Determination of the screw withdrawal resistance

### Screw selection

The standard screw size is: diameter 4mm, in and the length of the threads is 18 mm. This screw is suitable for coniferous species. For hard wood we recommend to use a smaller screw: diameter 3mm, in and the length of the threads is 15 mm. The screw withdrawal force is proportional to screw diameter and length of the threads.

### Preparation for the test

Drive the screw into the wood material, perpendicular to the material surface. You can use screwdriver or electronic driver tool (not included in the package). Screw withdrawal resistance is a local parameter. Select a location – based on visual inspection – which represents the whole wood sample. Avoid knot area and splits.

Force transducer has an integrated cable. Connect the cable to the display unit R320. Switch on the unit by pressing the “ON” button for 3 seconds. The unit is battery operated. The batteries are rechargeable, the charger is enclosed. Regarding the handling of the R320 unit please refer the enclosed operator manual. Please use Peak hold function, see page 11 at the R320 manual.

### Screw withdrawal process

Place the mechanics onto the screw. Catch the screw head by the fork of the force transducer. Slowly turn the handle clockwise until the screw is removed. In the beginning of the process place the mechanics in the proper position – means that the screw is the center of the withdrawal tool. The withdrawal force slightly depends on the speed of the test, so please apply the following speed: half turn in 3-4 seconds (around 0,5 mm/sec speed). Record the maximal force value and press the “Max” button before the next test to reset the display.

To save the batteries, please switch of the unit after use. If you forget to switch it of, after a few minutes it will sleep down automatically if the measured force value is unchanged.

## Maintenance

- Change the batteries when the "LowBat" message appears on the screen. If battery low, the unit switch off automatically.
- Once a year oiling of the mechanics sliding components is necessary.

## Guarantee

The guarantee is one year. If necessary, please order repair from Fakopp Enterprise Bt.: fax: +36 99 33 00 99 or e-mail: office@fakopp.com

## Technical parameters:

Force transducer capacity: 5 kN (survives 10kN)

- temperature sensitivity is less than 0,005%/K°
- hysteresis error less than 0,05%
- repetition error is less than 0,03%
- operation temperature:-10C° to +40 C°
- resistance: 350 Ω
- material: steel
- maker: Kaliber MM Kft., Budapest, Hungary

Force meter resolution is 5N

Display unit

- operation temperature: :+10C° to +40 C°
- Peak Max hold function
- battery operated (4 pieces of AA size 1.5 V battery)

Package includes:

- screw withdrawal mechanics with force transducer
- display unit, R320
- screwdriver
- Aluminum carrying box
- special screw:
  - diameter: 4mm, length of the threads is 18 mm (10)
  - diameter 3mm, length of the threads is 15 mm (5) for hard wood
- guide.

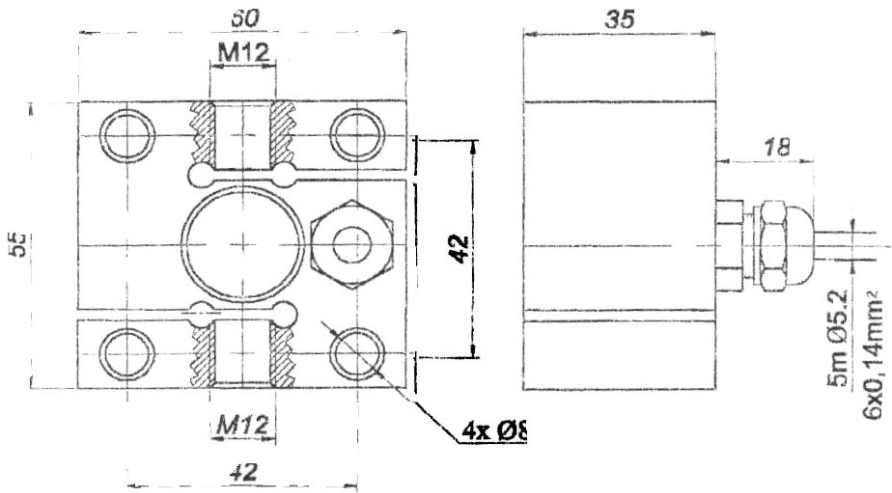

Dimensions of the force transducers